

INM61(368)-7

March 2001

# **HART Configurator**

Version 368-7

For Fuji FCX-A/C Series Pressure Transmitters

## **Instruction Manual**

HART is a trademark of the HART Communication Foundation

Copyright © BMS Technology 2000

# Index

- 1 Introduction
- 2 Preparation
- 3 Connect the Configurator
- 4 Calibrate
- 5 Range
- 6 Monitor
- 7 Test
- 8 Reset
- 9 Setup
- 10 Special Functions

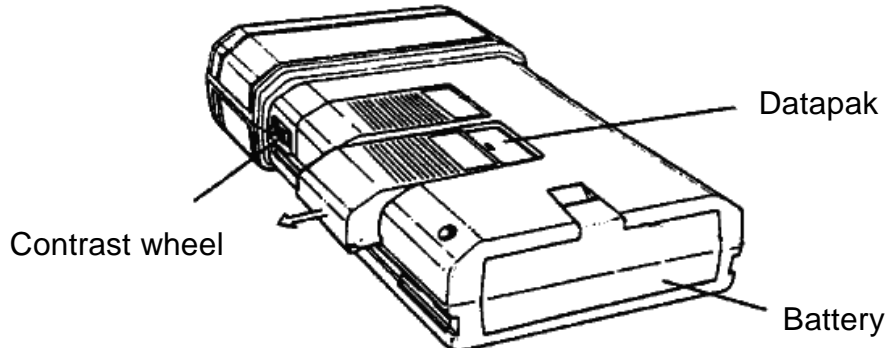

[www.bmstech.com/hart/](http://www.bmstech.com/hart/)

bmstech.com (Instruments Division) - part of the BMS Technology group  
55 High Street Telephone: +44 (0)7 010 700 020  
Tring HP23 5AG Fax: +44 (0)7 010 700 021  
England Email: info@bmstech.com

You have the non-exclusive right to use the Software. You may not copy the Software or any part of the Software. You shall endeavour to prevent any unauthorised use of the Software. The Software means computer programs, instruction manuals and documentation. All Industrial Property Rights in the Software or any part thereof, including patents, trademarks, trade names, copyrights and designs in relation to the Software and applications for such rights shall at all times remain vested in BMS Technology. BMS Technology shall be under no liability in respect of or arising out of the Software.

## 1 Introduction

With the configurator you can set up, test and calibrate instruments which use the HART protocol, as well as monitor process variables.

The configurator uses a pocket computer which also offers built-in functions such as calculator, diary and notes, and may also be used to run other software.

Configurator software is supplied in a Datapak. Each type of Datapak may be used with any HART instrument and also supports specific functions for one or more instrument type.

## 2 Preparation

You need an MTL611B or Psion Organiser LZ64 pocket computer, a CNF61 interface, CAB18 cable and a Datapak. The MTL611B is intrinsically safe; it may be taken into hazardous areas and connected to intrinsically safe instrument circuits.

Make sure a battery is fitted to the computer. Attach the CNF61 to the top and slide the Datapak into one of the slots at the back of the computer. Plug in the CAB18 cable.

Before taking the configurator into a hazardous area:

- Check the battery is suitable for IS use
- Remove any non-IS accessories
- Inspect for damage
- Switch on the configurator and check it works correctly

Press the ON key to switch on the computer. The menu should include "Hart" - if not, press the ON key again.

Adjust the display using the contrast wheel.

To switch off, go back to the main menu and press the letter O key.

## 3 Connect the Configurator

Clip the configurator cable onto your instrument loop. Select Hart from the main menu. The options for connecting the configurator are:

### 3.1 Connect

This is the normal way of connecting when there is only one instrument on the loop.

Select Connect to communicate with the instrument at address 0. While the configurator gets information from the instrument its details are shown, starting with the instrument serial number, description and the date (year/month/day) its configuration was last changed.

### 3.2 Scan

The HART protocol allows up to 15 instruments on a multi-drop loop (addresses 1 to 15). A single instrument on a loop should use address 0. The configurator scans all addresses 0 to 15. You can change the address of a scanned instrument. For example, if a multi-drop loop responds with an instrument at address 0, you can change its address via Setup.

Select scan. The address being scanned is shown. As instruments are found a list builds up on screen. You can interrupt scanning at any time by pressing ON.

Select an instrument using the arrow keys and press EXE. While the configurator gets information from the instrument its details are shown, starting with the instrument serial number, description and the date (year/month/day) its configuration was last changed.

### 3.3 Address

Select Address and enter the required address (0 to 15). Press EXE. While the configurator gets information from the instrument its details are shown, starting with the instrument serial number, description and the date (year/month/day) its configuration was last changed.

NB If you have another HART controller on the loop ensure that burst mode is off before connecting the configurator.

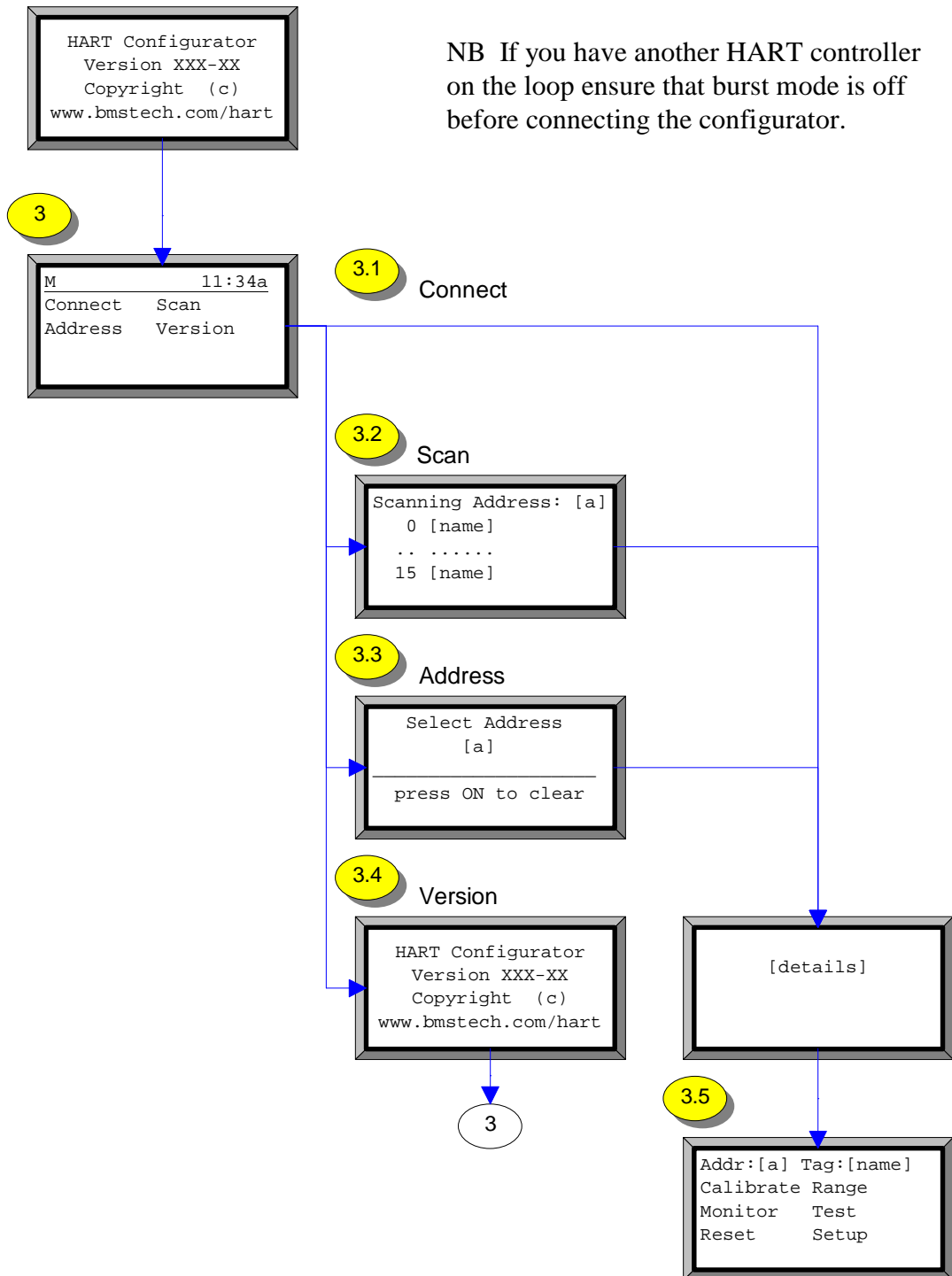

## 4 Calibrate

Connect the configurator then select Calibrate from the menu.

### 4.1 Warning

Make sure the signal you are calibrating is not used for control: set the controller to manual then press EXE. When calibration is finished set the controller back to automatic.

### 4.2 Set Zero

Select Set Zero. Apply a process input to the instrument equivalent to the zero (or range low) point then press EXE. The instrument zero is set at this input.

### 4.3 Trim Zero & Span

When one instrument is in the loop it adjusts its output (the loop current) between 4mA and 20mA. In a multi-drop loop instruments do not adjust the loop current: the trim feature is not available.

Select Trim Zero. The output is set to 4mA. Measure the loop current with a test meter; enter the reading on the configurator and press EXE. Repeat until the meter reading is 4mA plus or minus the instrument tolerance. The current is trimmed to compensate for minor errors. Press ON: the instrument output again tracks the process variable.

Similarly, select Trim Span and adjust until the meter reads 20mA.

### 4.4 Calibrate Zero & Span (some instruments only)

Select Calibrate Zero. Apply a process input to the instrument equivalent to the zero (range low) point, enter the process value then press EXE. The instrument zero is set at this value.

Select Calibrate Span. Apply a process input equivalent to the span (range high) point, enter the process value then press EXE. The instrument span is set at this value.

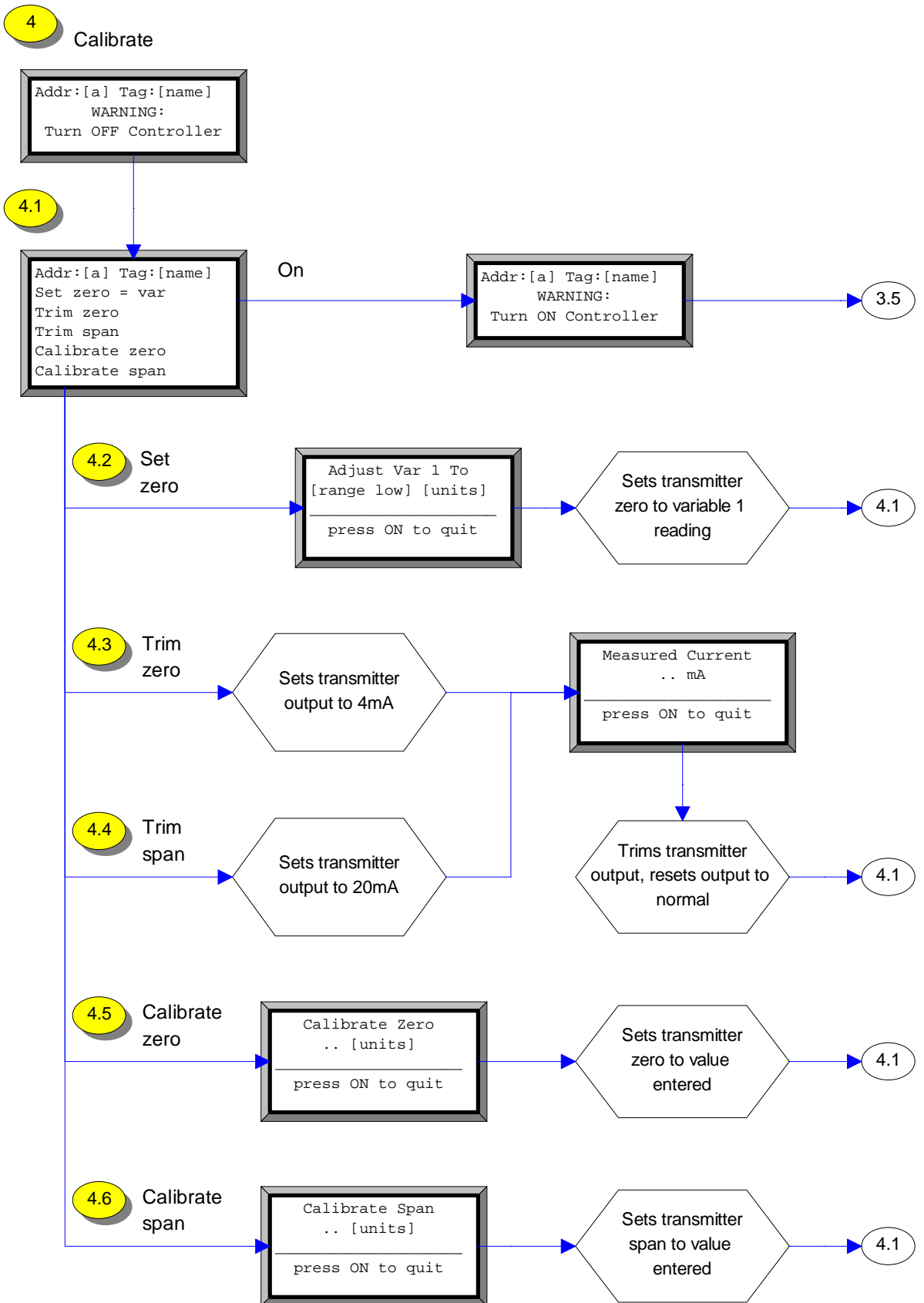

## 5 Range

Instruments measure a process variable between two values. For instance, a temperature transmitter has a range of -20°C to +180°C. The instrument's range may be set using the configurator.

Connect the configurator then select Range from the menu. The screen shows the range, the process variable and the same variable as a percent of the range, such as:

```
Var :      30.0°C
Zero:      -20°C
Span:      180°C
Var = 25% of range
```

Set the Zero first, then select Span or "Var % of range" to set the span.

### 5.1 Read Variable

Select Var to reread the process variable.

### 5.2 Zero

Select Zero. The screen shows the process variable and the zero (range low) value. Select Var to reread the process variable. Select Limits to see the low and high limits and the minimum span. Select Zero to enter a new value, or select Set Zero = Var to set the displayed process variable as the new zero.

### 5.3 Span

Select Span. The screen shows the process variable and the span (range high) value. Select Var to reread the process variable. Select Limits to see the low and high limits and the minimum span. Select Span to enter a new value, or select Set Span = Var to set the displayed process variable as the new span.

### 5.4 Span in Percent

Select "Var % of range". The top line shows the process variable. The bottom line shows the same variable expressed as a percent of the range. Enter a new percentage value then press EXE.

The displayed process variable becomes the percentage of the new range. For example, zero is 0 bar and the process variable is 0.4 bar; enter 50%; the range becomes to 0 to 0.8 bar.

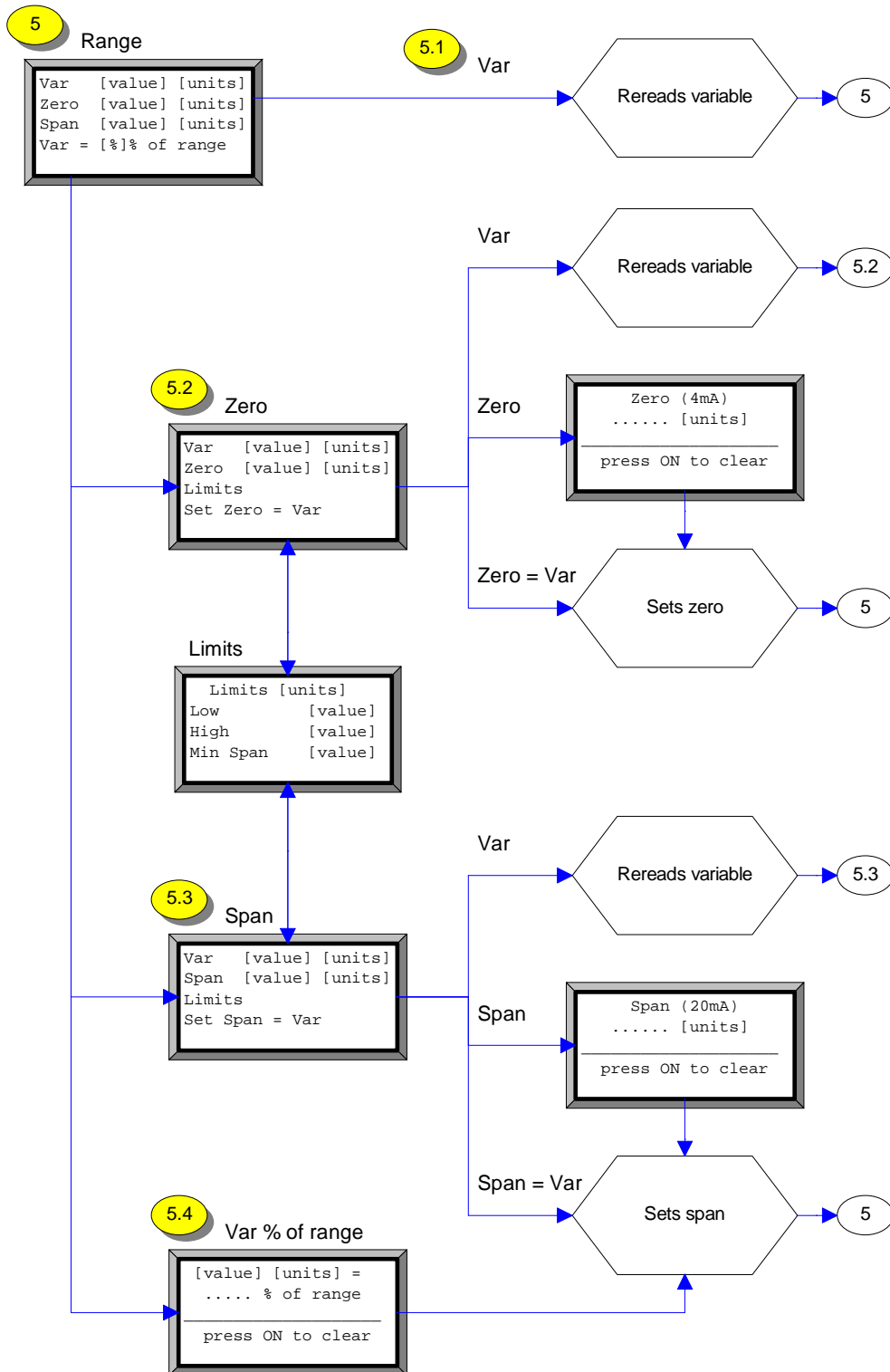

## 6 Monitor

Instrument variables may be monitored by the configurator.

Connect the configurator then select Monitor from the menu.

### 6.1 Current

Select Current. The loop current is displayed and reread periodically. This feature is available only for instruments at address 0 - in a multi-drop loop instruments do not adjust the loop current.

### 6.2 Variable 1

Select Var 1. The primary variable is displayed and reread periodically.

### 6.3 Variable 2

Select Var 2. Some instruments have a second variable: it is displayed and reread periodically.

### 6.4 Variable 3

Select Var 3. Some instruments have a third variable: it is displayed and reread periodically.

### 6.5 Variable 4

Select Var 4. Some instruments have a fourth variable: it is displayed and reread periodically.

Press ON to stop monitoring.

Section 10 gives details of any instrument-specific use of variables.

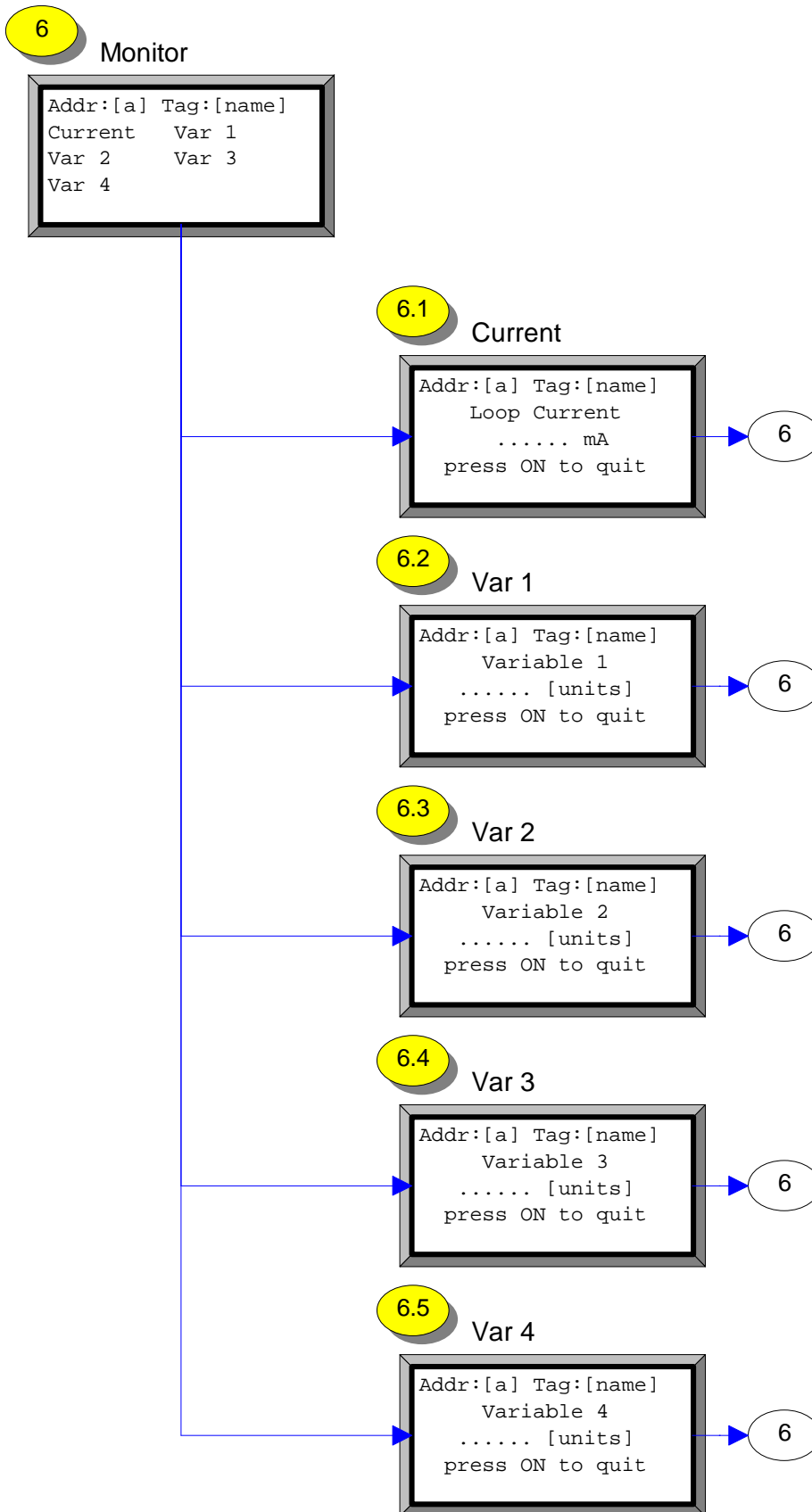

## 7 Test

Connect the configurator then select Test from the menu.

### 7.1 Communications

Select Communications. Messages are repeatedly sent to the instrument. The number of messages and the number of errors is shown. Press ON to stop the test.

### 7.2 Instrument

Test commands are sent to the instrument and the response examined. Diagnostic messages depend on the type of instrument.

### 7.3 Loop Current

The loop current may be set using the configurator. This feature is available only for instruments at address 0 - in a multi-drop loop the loop current stays fixed.

Select Loop current. Make sure the signal you are testing is not used for control: set the controller to manual then press EXE.

Enter a test current then press EXE. The instrument sets the current to the value displayed. Press ON: you can enter other values.

Press ON. The instrument output again tracks the process variable. You may now set the controller back to automatic: press EXE.

## 8 Reset

The instrument may be reset from the configurator. Connect the configurator then select Reset from the menu. Confirm you wish to reset by selecting Yes.

While the instrument is resetting its output may change and it will not respond to commands. Reset actions depend on the type of instrument.

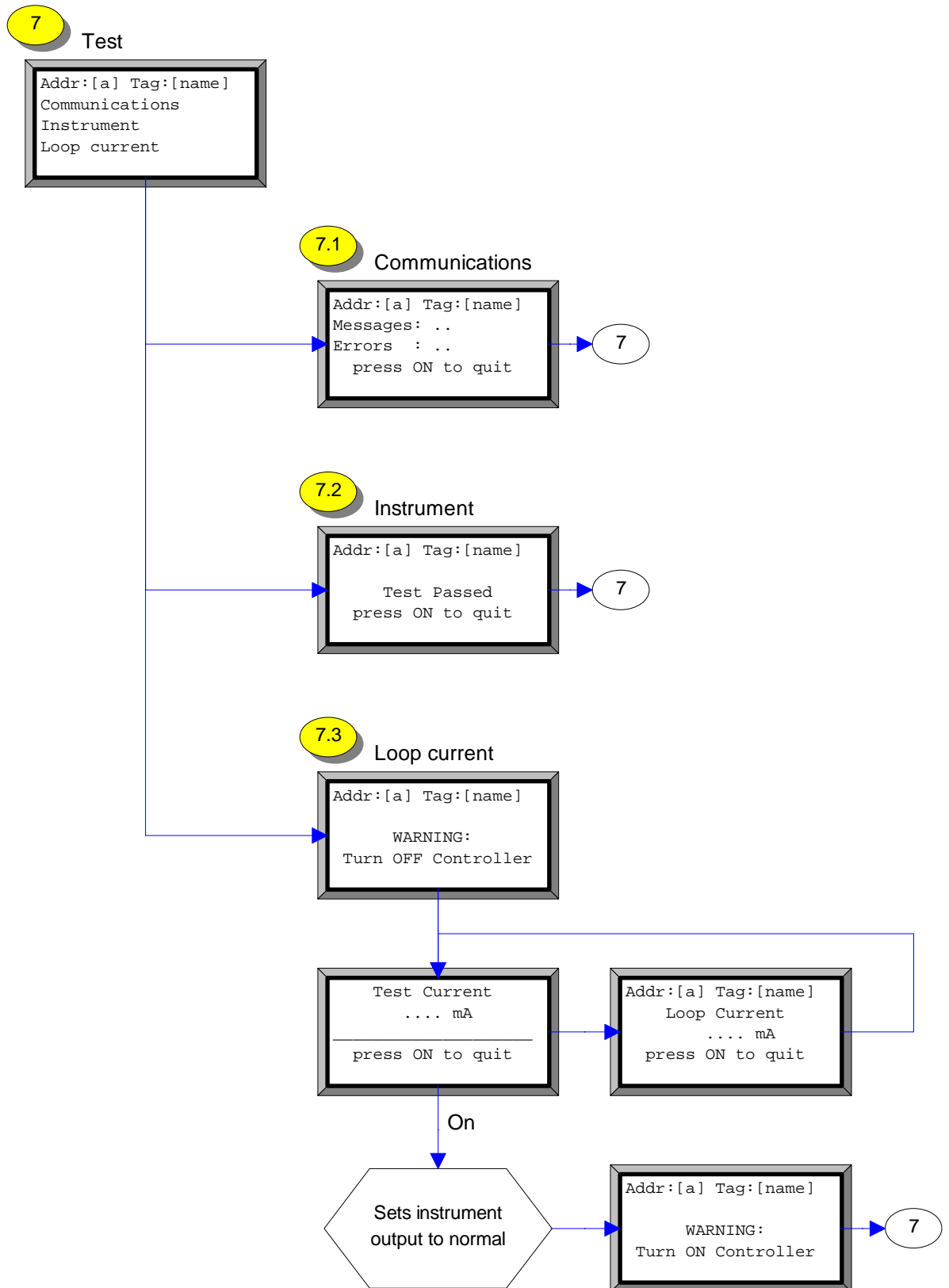

## 9 Setup

Connect the configurator then select Setup from the menu. See section 10 for special setup functions.

### 9.1 Address

Select Address. Press ON to clear. Then press ON to leave the instrument address unchanged or enter a new value then press EXE.

### 9.2 Tag Name

Select Tag. Press ON to clear. Then press ON to leave the tag name unchanged or enter a new tag then press EXE.

### 9.3 Description

Select Description. Press ON to clear. Then press ON to leave the instrument description unchanged or enter new text and press EXE.

### 9.4 Message

Select Message. Use the four arrow keys to view a long message. Press ON to clear. Then press ON to leave the message unchanged or enter new text then press EXE.

### 9.5 Transfer Function

Select Function. Some instruments allow different transfer functions (see section 10). Use the arrow keys then press EXE to change the transfer function or press ON to leave it unchanged.

### 9.6 Units

Select Units. Press ON to leave the process units unchanged or use the arrow keys then press EXE to change.

### 9.7 Damping

Select Damping. Some instruments let you enter a new value: press

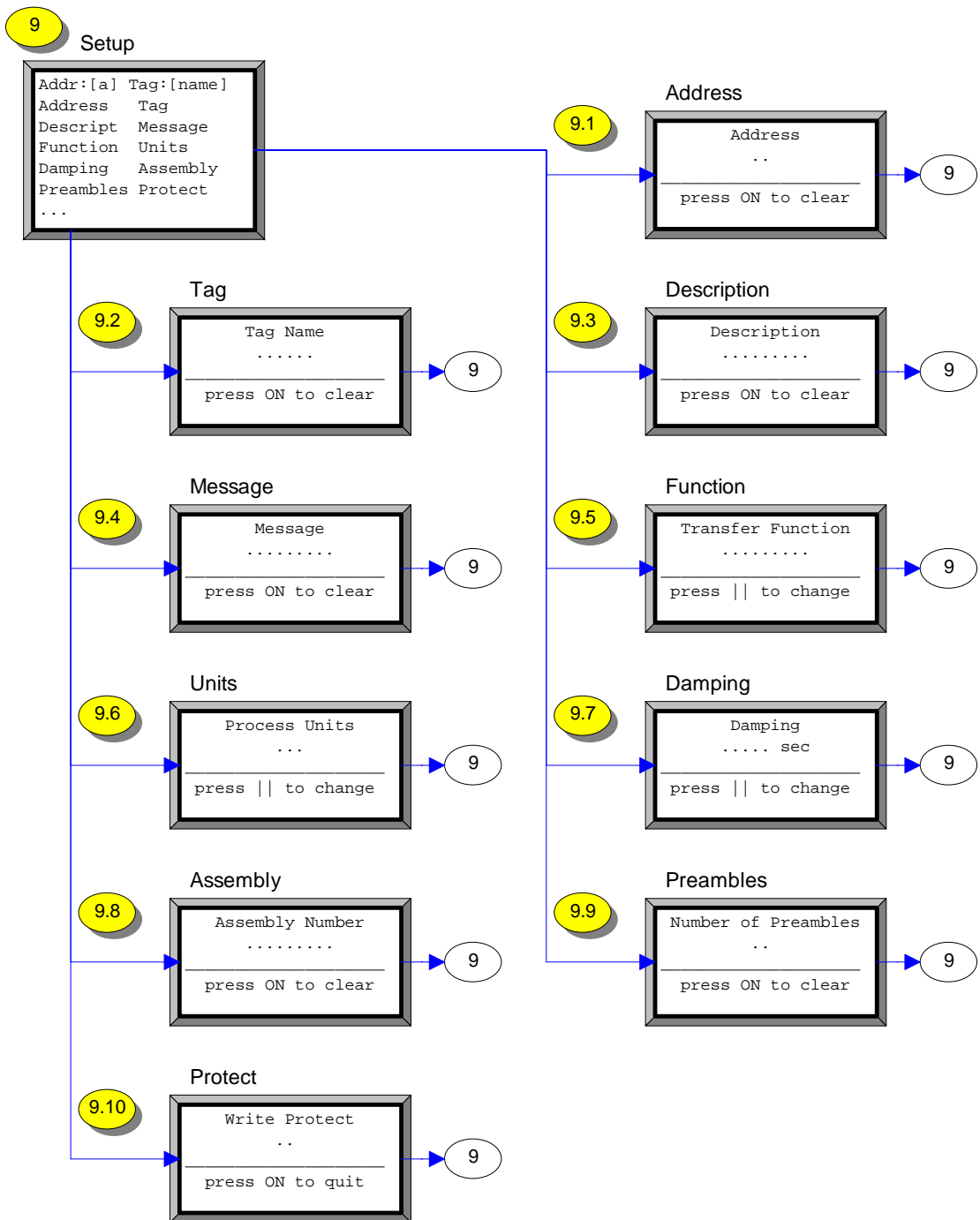

ON to clear then enter the new value and press EXE. Some instruments let you select a new value from a table: use the arrow keys then press EXE.

## 9.8 Assembly

Select Assembly. Press ON to clear. Then press ON to leave the assembly number unchanged or enter a new number then press EXE.

## 9.9 Preambles

Select Preambles. If the instrument allows preambles to be changed, press ON to clear then enter a new number and press EXE.

### 9.9.1 Protect

Select Protect. The write protect status is shown. It cannot be changed. Press ON to return to the setup menu.

## 10 Special Functions

When you are connected to an instrument with special functions, additional selections appear on the setup menu. This Datapak supports special functions for Fuji FCX-A/C series pressure transmitters.

### 10.1 Variables

Var 2 is the transmitter's internal temperature.

### 10.2 Transfer Function

The output (variable 1) and the display may each be set to linear or square root.

### 10.3 Display

Select Display. The type of display should match the display installed:

Digital Display EU	Digital display in engineering units
Digital Display %	Digital display in percent
Analog Meter EU	Analog display in engineering units

Analog Meter %      Analog display in percent  
Press ON to return to the setup menu, or if the type of display is incorrect select a type by pressing the arrow keys then press EXE.

#### **10.4      Local Key**

Select Local key. When the local key is enabled you can alter the zero using the adjusting screw on the instrument. When the local key is disabled, the adjusting screw has no effect. Press ON to leave the local key as it is, or EXE to change.

#### **10.5      Burnout**

Select Burnout. The burnout (or alarm) mode is shown: Fail Low, Fail High or Fail Fixed. Press ON to return to the setup menu. The mode cannot be changed here - see the instrument manual.

#### **10.6      Module**

Select Module. The type of construction of the module is shown, such as Differential (DP). This is set in the factory and cannot be changed. Press ON to return to the setup menu.

#### **10.7      Maximum Range**

Select Max range. The maximum usable pressure range is shown. It cannot be changed from here. Press ON to return to the setup menu.

#### **10.8      Materials**

Select Materials then select a part. The material for that part is shown and may be changed for some parts. Press ON to leave the component as shown or use the arrow keys then press EXE to change.